

Brake Caliper HS 145 FHM-260 ... -H

spring activated – hydraulically released

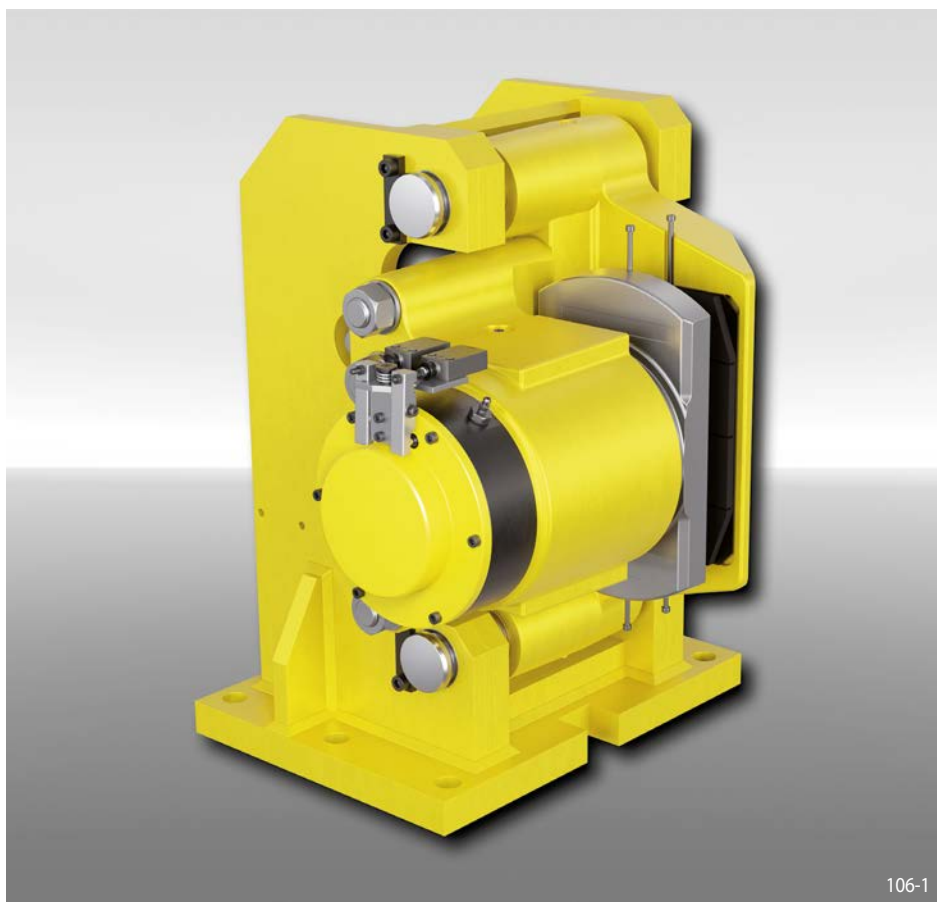

106-1

Features	Code
Brake Caliper	H
Floating caliper	S
Frame size 145	145
Spring activated	F
Hydraulically released	H
Manual adjustment to accommodate friction block wear	M
Max. clamping force 260 kN	260
Thruster mounted right or left available	R L
Mounting to the machine at right angles to the brake disc	H

Example for ordering

Brake Caliper HS 145 FHM, max. clamping force 260 kN, thruster mounted left, mounting to the machine at right angles to the brake disc:

HS 145 FHM-260 L-H

Technical Data

Brake disc diameter	Braking torque
mm	Nm
700	54 900
800	65 400
1 000	86 600
1 250	112 900
1 600	149 900
2 000	192 100
3 000	297 700
3 500	350 400
4 000	403 200
Clamping force	260 kN
Oil pressure	min. 230 bar max. 250 bar
Oil volume	max. 40 cm ³
Thickness of brake disc W	30 mm
Weight	330 kg

The braking torques shown in the table are based on a theoretical friction coefficient of 0,4.

Working conditions

- Ambient temperature: -20 °C / +60 °C
- Air humidity: <90%

Monitoring switch

- 240 VAC 1.5 A; 250 VDC 0.1 A
- Cable 5 x 0.75 mm², length 2 m, outer diameter 7.5 mm
- Protection type IP67

Options

- Integrated Hydraulic Power Unit
- Friction pads with wear indicator cables or sintered friction linings (for high temperatures)
- Corrosion-protected version
- Low temperature version
- Offshore certifications
- ATEX certifications for hazardous areas

Notes

- Eyebolts included
- Fastening:
6 screws M24, class 8.8 with tightening torque 630 Nm ±10% μ 0.15 (not supplied)

Brake Caliper HS 145 FHM-260 ... -H

spring activated – hydraulically released

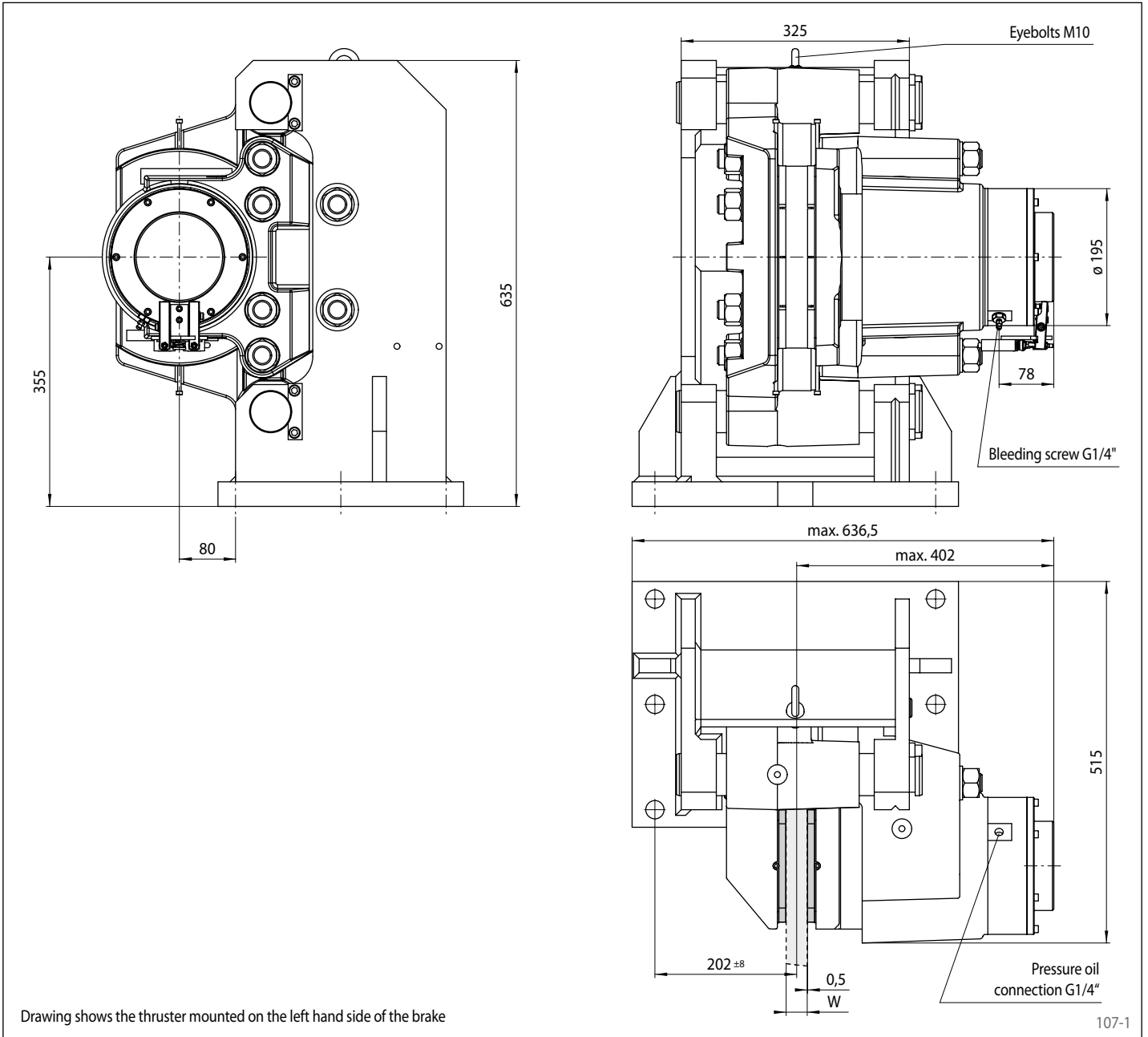

Mounting

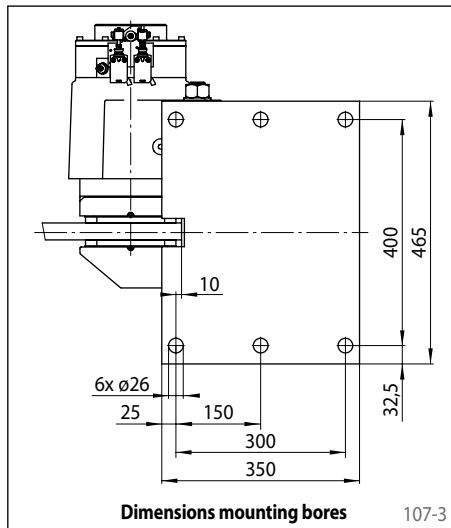
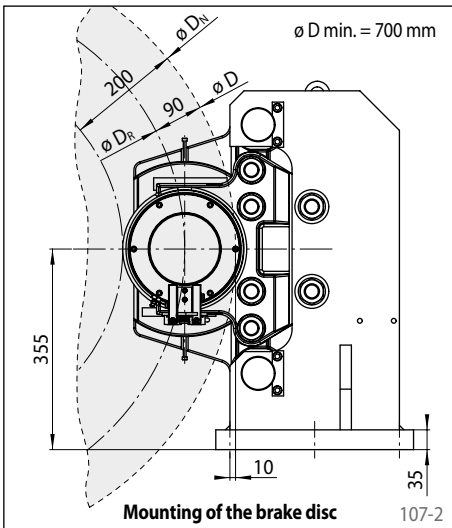

Calculation of the friction diameter

$$D_R = D - 180 \text{ mm}$$

Calculation of the hub diameter

$$D_N = D - 400 \text{ mm}$$

Calculation of the braking torque

$$M_B = F_K \cdot D_R \cdot \mu$$

Formula symbols

D = Outer diameter brake disc [mm]

D_N = Hub diameter [mm]

D_R = Friction diameter [mm]

F_K = Clamping force [N]

M_B = Braking torque [Nm]

μ = Friction coefficient