

Brake Caliper DH 020 FPM

spring activated – pneumatically released



Features

Features	Code
Brake Caliper	D
Mounting to the machine at right angles to the brake disc	H
Frame size 020	020
Spring activated	F
Pneumatically released	P
Manual adjustment to accommodate friction block wear	M
Thrusters 020, 030 or 040 are available	020 030 040
Position of the thruster to the right or left can be defined by turning the brake during installation	U
Thickness of brake disc 12,5 mm	12

Example for ordering

Brake Caliper DH 020 FPM, thruster 020, position of the thruster can be to the right or left, thickness of brake disc 12,5 mm:

DH 020 FPM - 020 U - 12

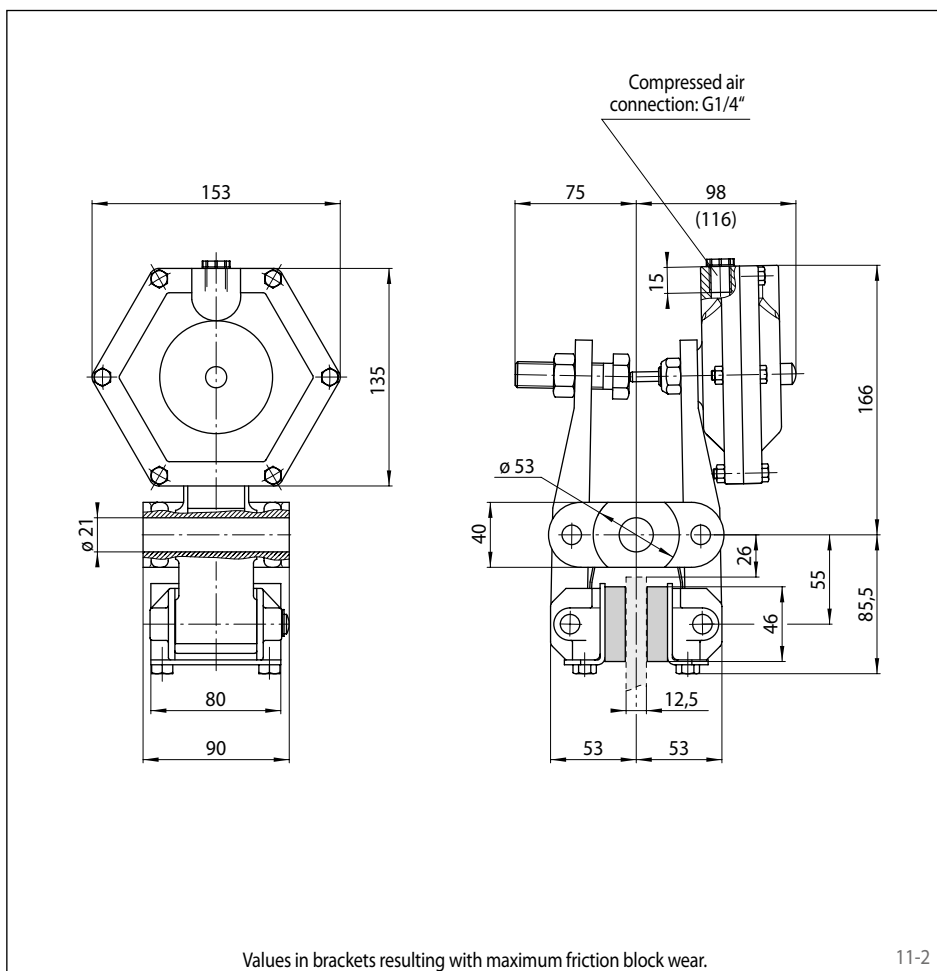

Technical Data

Brake disc diameter	Brake Caliper DH 020 FPM		
	with thruster 020	with thruster 030	with thruster 040
mm	Braking torque Nm	Braking torque Nm	Braking torque Nm
200	97	130	200
250	130	180	270
300	170	220	340
355	200	270	420
430	250	340	520
520	310	430	650
Clamping force	1700 N	2300 N	3500 N
Air pressure	min. 2,6 bar max. 7 bar	min. 3,5 bar max. 7 bar	min. 5 bar max. 7 bar
Air volume per activation	max. 17 cm ³	max. 17 cm ³	max. 17 cm ³
Weight	5,2 kg	5,2 kg	5,2 kg

The braking torques shown in the table are based on a theoretical friction coefficient of 0,4.

Values in brackets resulting with maximum friction block wear.

11-2