

Brake Caliper DH 012 FEM

spring activated – electromagnetically released



Figure shows product with inductive proximity switch: "Brake released"

78-1

Features

Features	Code
Brake Caliper	D
Mounting to the machine at right angles to the brake disc	H
Frame size 012	012
Spring activated	F
Electromagnetically released	E
Manual adjustment to accommodate friction block wear	M
Electromagnet for 110/120 VAC	440
Electromagnet for 230/240 VAC	450
Electromagnet mounted right or left available	R L
Thickness of brake disc 12,5 mm	12

Example for ordering

Brake Caliper DH 012 FEM, electromagnet for 110 V, electromagnet mounted right, thickness of brake disc 12,5 mm:

DH 012 FEM - 440 R - 12

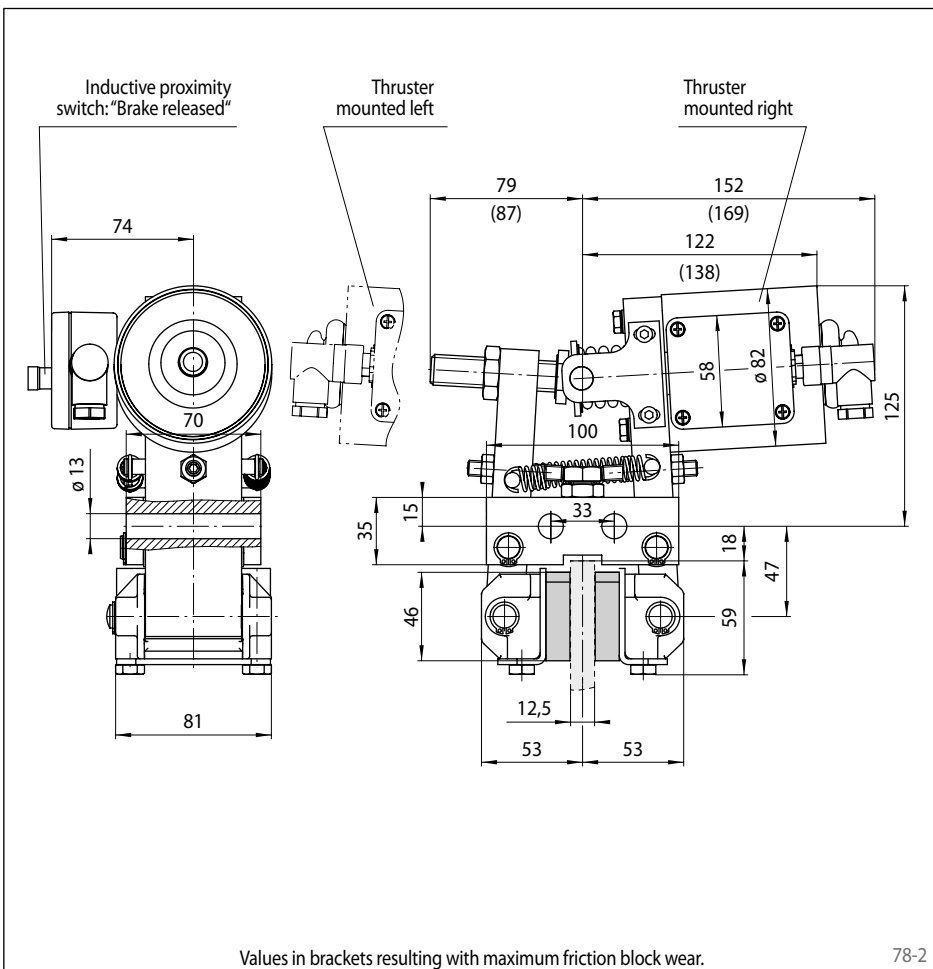

78-2

Technical Data

	Brake Caliper DH 012 FEM	
	with electro-magnet 440 for 110/120 V	with electro-magnet 450 for 230/240 V
Brake disc diameter mm	Braking torque Nm	
200	110	
250	140	
300	180	
355	220	
430	280	
520	340	
Clamping force	1850 N	
Response time*	200 ms	
Power consumption in open position	10 W (100% duty factor)	
Fuse rating	6A	
Max. number of actuation	600/h permanent activations at 20° C ambient temperature	
Weight	7 kg	

The braking torques shown in the diagram are based on a theoretical friction coefficient of 0,4.

* The response time is the duration from switching off the power supply to reaching 80% of the maximum clamping force (at Ta = 20 °C).

Accessories

Universal Transformer see page 204.

Options

- Available with cCSAus approval
- Inductive proximity switch: "Brake released"